

D3 SOLAS

Volvo Penta has a powerful SOLAS approved range for use in fast rescue boats: the D3-110 to D3-220 common rail marine diesel engines with rating 5 power settings. The engines are SOLAS approved for both inboard, waterjet and sterndrive propulsion.

Designed to withstand the tough Life- and Rescue boat environment

The D3 Life- and Rescue boat engines are designed to comply with the requirements in the following regulations and standards:

- Council Directive 96/98/EC, as amended by Commission Directive 2009/26/EC
- SOLAS 74 Convention, as amended, Reg. III/4 and Reg. III/34
- LSA Code
- IMO Resolution MSC. 48(66)
- IMO Res. MSC. 81(70), Part 1, paras. 6.10.2 to 6.10.6 and 6.14.6 to 6.14.8.

SOLAS specifications

The SOLAS regulations specify the following demands for the engine:

- Withstand free fall of the lifeboat from 3 meters
- Withstand a lateral impact of 3.5 m/s of the lifeboat
- Stop automatically on capsizing and easily restart
- Fuel and lubricating systems shall prevent the loss of fuel and oil during capsizing
- Work submerged in water to the crankshaft centerline
- Work for not less than 5 min. after starting cold with the lifeboat out of the water
- Run properly at an angle of up to 10° trim and an angle of up to 20° list, either way
- Manual starting system or power starting system with two independent sources
- The lifeboat engine shall be designed to limit electromagnetic emissions
- The engine to be started without heater down to -15°C (-30°C with heater)
- For gear & sterndrives, see note



Standard high performance engines

All SOLAS engines are based on standard engine designs with SOLAS kits mounted and are tested in factory before delivery to boat builders.

The SOLAS kit also includes a tilt switch, to be mounted on the engine bulkhead.

The base engine mounts are originally designed for high G-forces. Thus, there is no need for extra reinforcement for fast rescue boats and lifeboat applications to meet the SOLAS demands.

EVC for full control in all situations

All engines are equipped with EVC including electronic shift controls, the latest development in engine control and instrumentation for Volvo Penta marine engines, for easy installation and easy handling. For self rightning boats, see note.

A propulsion package fully matched, tested and supported by one company

The engines and the drives are developed and produced by Volvo Penta, and the service of the engines will be well taken care of by more than 5,000 Volvo Penta commercial and leisure dealers around the world.

Low emissions

The piezo electric injectors in combination with the 1800 bar common rail system are setting new standards in minimizing noxious emissions and particulates. The engines comply with IMO Tier 2 NOx limits and the comprehensive emission requirements EU RCD and US EPA Tier 3 (Marine Leisure).

Certificate

The engines will be delivered with a certificate and marked with a wheelmark in accordance with the MED/SOLAS regulations. For the installation, see note.

D3 SOLAS

Technical description

For full technical information and performance data for the D3 engines, please see the product leaflets and technical data sheets for the selected power setting and model of D3.

Technical Data

Crankshaft power + dry weight BT inboard

D3-110:

@ 3000 rpm, kW (hp) 81 (110)
kg (lb) 260 (573)

D3-140:

@ 4000 rpm, kW (hp) 103 (140)
kg (lb) 260 (573)

D3-150:

@ 4000 rpm, kW (hp) 110 (150)
kg (lb) 260 (573)

D3-170:

@ 4000 rpm, kW (hp) 125 (170)
kg (lb) 260 (573)

D3-200:

@ 4000 rpm, kW (hp) 147 (200)
kg (lb) 260 (573)

D3-220:

@ 4000 rpm, kW (hp) 162 (220)
kg (lb) 260 (573)

Battery

Minimum requirements for cold start:
2 x 760 CCA.

Cold starting device

2 kW engine coolant heater to be installed for coldstarts below -15°C (down to -30°C)

Reverse gear

- Reverse gear with matched drop center and 8° down angle for compact installation and minimum propeller shaft angle.
- Bevel gears which results in smooth running at all speeds
- Hydraulically operated clutch for smooth shifting
- Electrical shifting performed by electromagnetic valves
- Seawater-cooled oilcooler

Waterjet

- For selection of waterjet please contact your waterjet dealer.

Sterndrive SX/DPS

- Single propeller drive which can be run with both right- or left-hand propellers (SX, 140-170 hp)
- A variety of Duoprop propellers are available (DPS, 140-220 hp)

- Cone clutch
- Pattern-matched spiral bevel gears
- Complete connection for exhaust outlet through propeller hub and cavitation plate
- Overload protection sleeve (break-away coupling)
- Max tilt angle 52°
- The drive can be turned 28° in each direction
- Built-in kick-up function to reduce possible damage, in the event the drive strikes an underwater object
- Active corrosion protection as accessory
- Integrated speedometer (pitot tube) pickup in lower drive leg
- Easy to access drive anode placed on the back of the cavitation plate

NOTE

The SOLAS kit only covers certification of the engine, not the installation. For self righting boats following needs must be arranged by the yard:

- Sea water safe controls and display
- Exhaust system designed to avoid water ingress when capsizing
- Propeller protection
- Heating of sterndrive and gear in cold temperatures below -15°C

Dimensions

Dimensions shown are dimensions for SOLAS version of D3. Not for installation. For detail dimensions, see D3 installation drawing and assembly instructions.

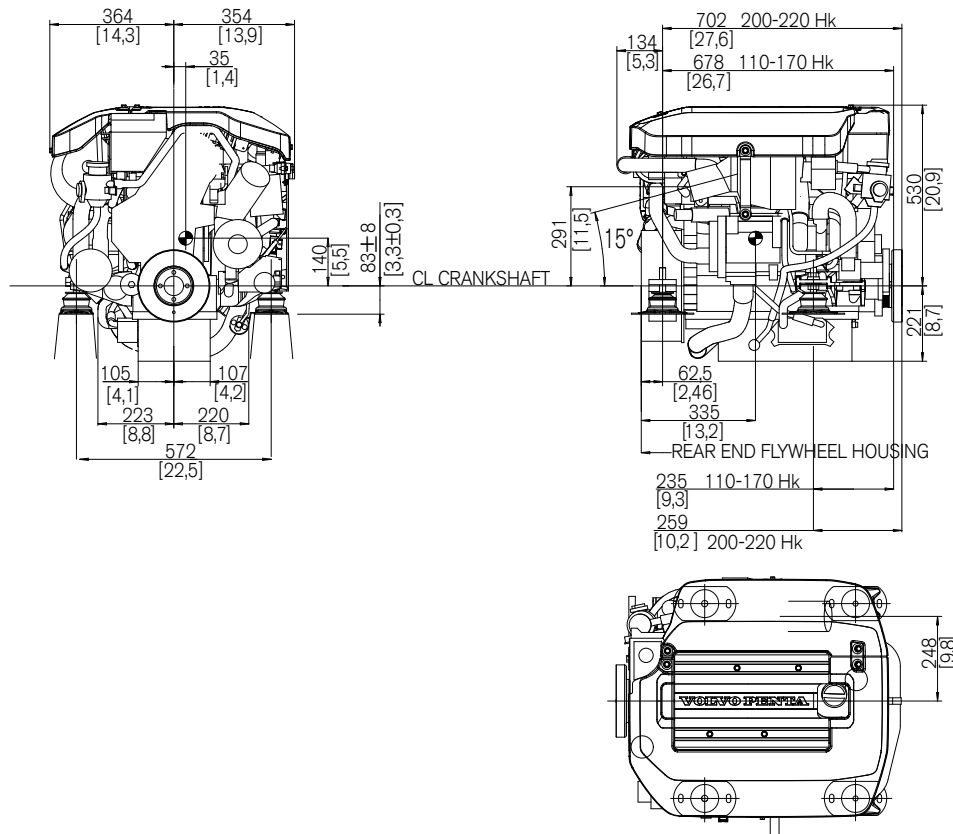

Contact your local Volvo Penta dealer for further information. Not all models, standard equipment and accessories are available in all countries. All specifications are subject to change without notice. The engine illustrated may not be entirely identical to production standard engines.

VOLVO PENTA

AB Volvo Penta

SE-405 08 Göteborg, Sweden
www.volvopenta.com